

PLAN

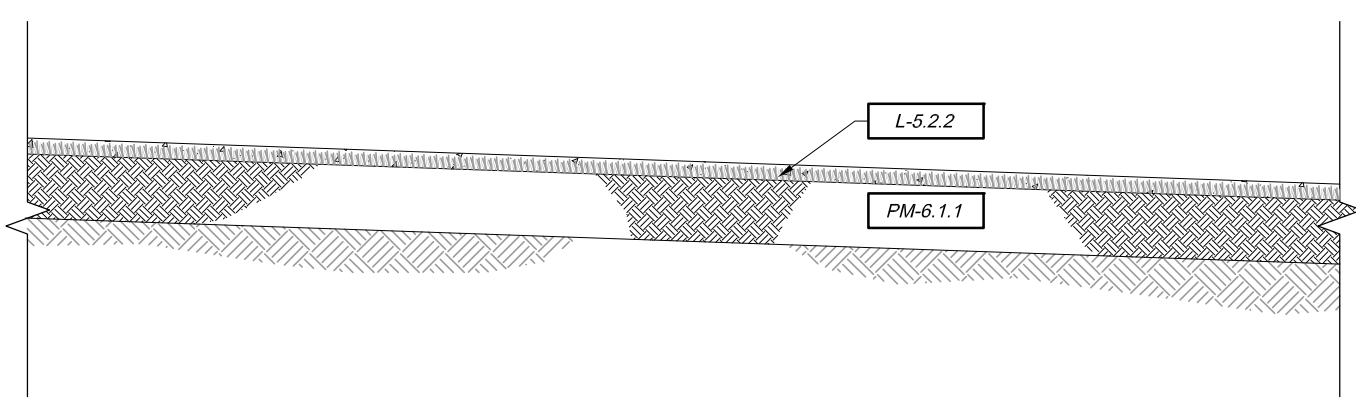

PROFILE

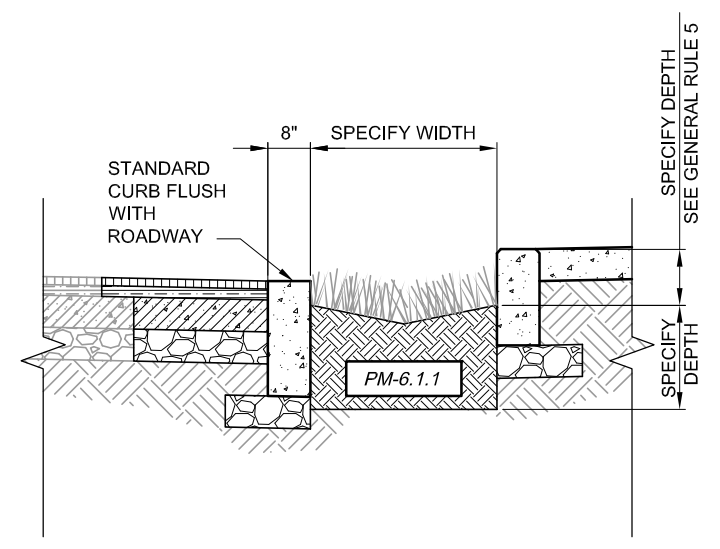

SECTION A-A

NOTES TO DESIGNER

1. This design detail should be adapted to the specific engineered design and its respective installation.
2. Consider adding rumble strips or cobble to the curb adjacent to and flush with the street to give an additional cue about change in gutter surface. A raised curb with openings may be used and may be more appropriate for certain conditions in lieu of flush curb.

APPLICABLE DESIGN COMPONENTS

- (L) Landscaping
- 5.2.2 Plants, Grasses, and Shrubs
- (PM) Planting Media
- 6.1.1 Engineered Soil